

Montageanleitung VISION® 180 SB VISION® 260 SB VISION® 450 SB

Assembly instructions
Instructions de montage
Montage handleiding
Istruzioni per il montaggio
Instrukcja montażu
Инструкция по монтажу
安裝說明

JUWEL AQUARIUM GMBH & CO. KG
Karl-Göx-Straße 1 · D-27356 Rotenburg/Wümme
Telefon +49 (0) 42 61/ 93 79-0
Telefax +49 (0) 42 61/ 93 79-856

Service-Hotline (0 18 05) AQUARI / (0 18 05) 27 82 74
Service-Mail service@juwel-aquarium.de

JUWEL AQUARIUM (UK) Ltd.
Gateway 11 Business Park
Penfold Drive, Wymondham · Norfolk NR18 0WZ
Tel.: 01953 606 363 · Fax: 01953 603 839

E-Mail: info@juwel-aquarium.co.uk
Service-Mail: info@juwel-aquarium.co.uk

Technische Änderungen vorbehalten.
We reserve the right to make technical alterations.
Sous réserve de changements technique ultérieurs.
© JUWEL AQUARIUM

101 015/0604

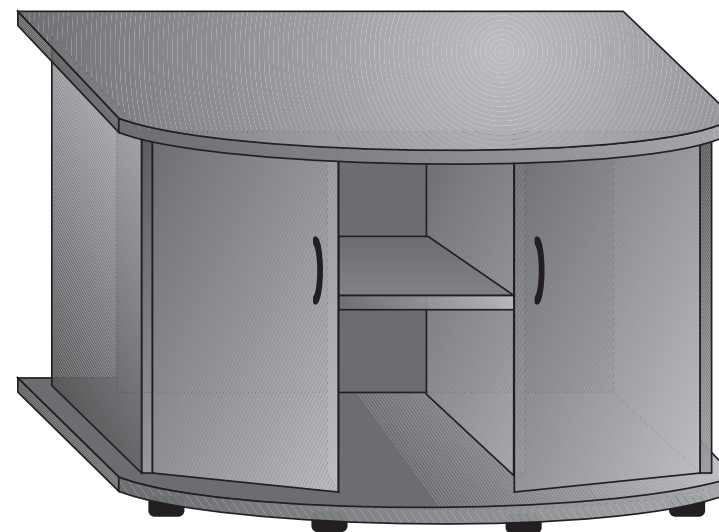

www.juwel-aquarium.com



